

Maxstar® 150 S

Issued Feb. 2004 • Index No. DC/27.0

Stick Welding
Power Source 

Quick Specs

Light Industrial Applications

Maintenance Repair
Shipboard Installation/Repair
Farm/Ranch
Hobbyist

Processes

Stick (SMAW)

Input Power 1-Phase Power

Amperage Range 115 VAC: 20–100 A (DC)
230 VAC: 20–150 A (DC)

Max. Open-Circuit Voltage 90

Weight 13.2 lb (6.0 kg)

The Power of Blue.®



NEW! Low OCV Stick is a simple design that reduces the open-circuit voltage to 12–16 volts when the welding power source is not in use. This circuit design is now built into the Maxstar 150 S eliminating the need for add-on voltage reducers.

Portable in the shop or at the job site — at 13.2 lb the shoulder strap allows the end user to easily move from location to location.

Thermal overload protection with indicator light helps prevent machine damage if the duty cycle is exceeded or airflow is blocked.

Single amperage range allows operator to accurately set amperage on both 115 or 230 V primary power.

Inverter-based, DC power source has a **simple-to-use operator interface** providing only the necessary controls in a compact machine.



Maxstar® 150 S with case (#907 134-01-1) shown.

Base Unit (#907 134) Comes Complete With:

Power source with cord, 13 ft (4 m) stick electrode holder, 10 ft (3 m) work clamp, and shoulder strap.

Easy installation — Auto-Line™ provides state-of-the-art flexibility to the end user. The Auto-Line circuitry automatically connects to 115–230 VAC, single-phase power without removing the covers to relink the power source. No longer is there a concern if you have the correct machine for the shop or job site.

Adaptive Hot Start™ for Stick arc starts automatically increases the output amperage at the start of a weld should the start require it. Prevents the electrode from sticking and creating an inclusion.

Best in class Stick arc characteristics for those demanding jobs.



Power source is warranted for 3 years, parts and labor.
Original main power rectifiers are warranted for 5 years.

MADE IN **USA**
APPLETON, WI



Miller Electric Mfg. Co.
An Illinois Tool Works Company
1635 West Spencer Street
Appleton, WI 54914 USA

International Headquarters
Phone: 920-735-4505
USA FAX: 920-735-4134
Canadian FAX: 920-735-4169
International FAX: 920-735-4125

Web Site
www.MillerWelds.com



Specifications (Subject to change without notice.)



Input Power	Rated Output	Welding Amperage Range	Max. Open-Circuit Voltage	Amps Input at Rated Output, 50/60 Hz	KVA at Duty Cycle	KW	Dimensions	Weight
115 VAC	70 A at 22.8 VDC, 100% Duty Cycle	20–100 A	90, 12–16 V*	17.4	2.0	1.9	H: 9 in (229 mm) W: 5-1/2 in (140 mm) D: 13-1/4 in (337 mm)	13.2 lb (6.0 kg)
	100 A at 24.0 VDC, 35% Duty Cycle			26.4	3.0	3.0		
230 VAC	100 A at 24.0 VDC, 100% Duty Cycle	20–150 A	90, 12–16 V*	13.1	3.0	2.8		
	150 A at 26.0 VDC, 30% Duty Cycle			21.6	4.9	4.7		

*Sense voltage for Stick.

Certified by Canadian Standards Association to both Canadian and U.S. Standards.

Control Panel

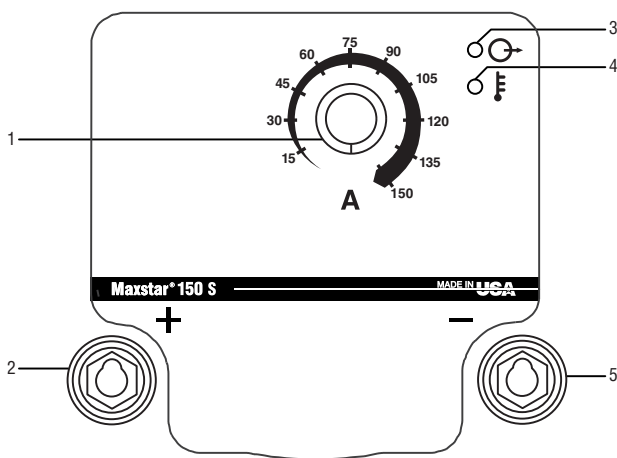

1. Amperage Adjustment Control
2. Positive Weld Output Receptacle
3. Ready Light
4. Overtemperature Light
5. Negative Weld Output Receptacle

Performance Data

DUTY CYCLE CHART

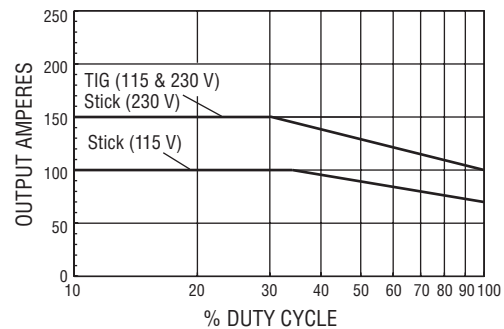

VOLT/AMP CURVES

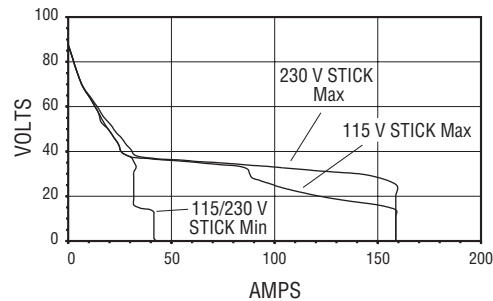

Ordering Information

Power Source and Options	Stock No.	Description	Qty.	Price
Maxstar® 150 S	#907 134	Single-phase, 115–230 VAC, 50/60 Hz, includes 13 ft (4 m) electrode holder, 10 ft (3 m) work clamp, shoulder strap and primary cord		
	#907 134-01-1	Includes #907 134 plus carrying case		
Accessories				
Carrying Case	#195 180	Case only		

Date: _____ Total Quoted Price: _____

Distributed by:

